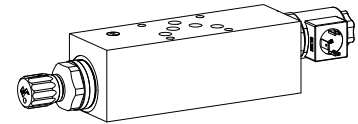

**Fine feed-/fast approach valve
 Sandwich construction**

- Q_{max} = 80 l/min (Fine feed)
- Q_{max} = 120 l/min (Fast approach)
- Q_{Nmax} = 70 l/min
- p_{max} = 350 bar

NG10
 ISO 4401-05

DESCRIPTION

Fine feed-/fast approach valve in sandwich construction. 2-way flow control cartridges (see data sheet 2.5-550) and 2/2-way solenoid poppet valve cartridges 1.11-2076 are installed. 2 standard nominal volume flow ranges are available. The sandwich body made of steel is phosphatized.

FUNCTION

The fine feed-/fast approach valve serves for the electrically controlled two-stage speed control. Fine feed and fast approach. At the fine feed the volume flow is controlled by the flow control valve, to the manually adjusted value independent on the load. In doing so, the poppet valve is closed. At the fast approach the volume flow, dependent of the load and of the system pressure, flows through the poppet valve.

APPLICATION

The fine feed-/fast approach valves are utilised in hydraulic systems, which require an electrically controlled fine feed-/fast approach changeover, such as positioning controls on machine tools or elevation controls of elevating platforms, etc. Due to the sandwich construction, these fine feed-/fast approach valves can be integrated into stacked systems as an intermediate flange.

TYPE CODE

Fine feed- / fast approach valve		V		Q	□	S	A10	-	□	□	-	□	-	□	/	W	□	#	□
Flow control function																			
Type of adjustment		Key		S															
		Control knob		D															
Sandwich construction																			
International standard interface ISO, NG10																			
Type list / Function																			
		in P		P		Meter-out flow control		Meter-in flow control in											
		in T		T		in A		in A		AV									
						in B		in B		BV									
Poppet valve		Normally closed		C															
		Normally open		O															
Nominal volume flow rate Q_N		32 l/min		32															
Flow control valve		70 l/min		70															
Nominal voltage U_N		12VDC		G12		115VAC		R115											
		24VDC		G24		230VAC		R230											
Slip-on coil		Metal housing round																	
Connection execution		Connector socket EN175301-803/ISO 4400		D															
		Connector socket AMP Junior-Timer		J		(only for $U_N \leq 75$ VDC)													
Design index (subject to change)																			

GENERAL SPECIFICATIONS

Description	Fine feed-/fast approach valve
Nominal size	NG10 acc. to ISO 4401-05
Construction	Sandwich construction
Mounting	4 holes for socket cap screws M6 or studs M6
Connection	Threaded connection plates, multi-flange subplate, stacking system
Ambient temperature	-20 ... +50 °C
Mounting	any
Fastening torque	$M_D = 9,5$ Nm (Qual. 8.8) for fixing screws cartridges: see valve data sheets
Weight	$m = 4,5$ kg

HYDRAULIC SPECIFICATIONS

Fluid	Mineral oil, other fluid on request
Contamination efficiency	ISO 4406:1999, class 18/16/13 (Recommended filtration grade $\beta_{6...10} \geq 75$) refer to data sheet 1.0-50/2
Viscosity range	12 mm ² /s...320 mm ² /s
Fluid temperature	-20...+70 °C
Peak pressure	$p_{max} = 350$ bar
Nominal volume flow rates	$Q_N = 32$ l/min, 70 l/min
Min. volume flow	$Q_{min} = 0,2$ l/min
Max. volume flow	$Q_{max} = 120$ l/min

For further hydraulic specifications, refer to flow control valve data sheet 2.5-550.

ELECTRICAL ACTUATION

Solenoid construction: see data sheet poppet valve (1.11-2076)

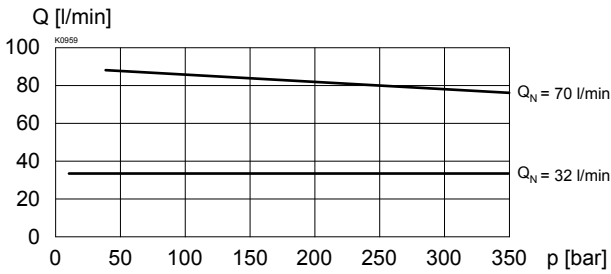
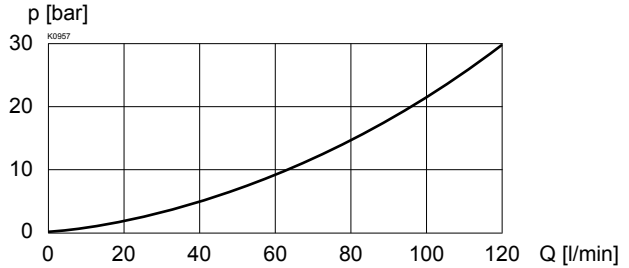
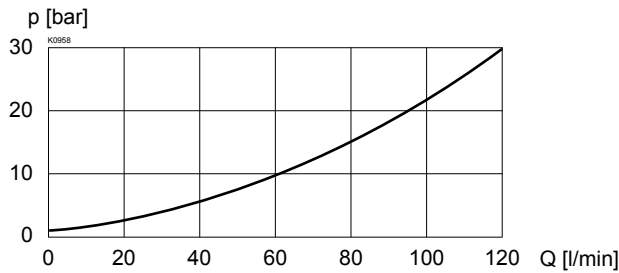
CHARACTERISTICS Oil viscosity $\nu = 30 \text{ mm}^2/\text{s}$
 $Q = f(p)$ Volume flow pressure characteristics (Fine feed)

 $\Delta p = f(Q)$ Pressure drops volume flow characteristic (Fast approach)

 $\Delta p = f(Q)$ Pressure drop volume flow characteristic over non-return valve function of poppet valve

SCREW-IN CARTRIDGES INSTALLED

The following screw-in cartridges are used in the sandwich body:

Type	Designation	Data sheet no.
QZ.PM33	Flow control valve	2.5-550
SVSPM33	Solenoid poppet valve	1.11-2076

PARTS LIST

Position	Article	Description
10	160.2140	O-ring ID 14,00 x 1,78 (NBR)

ACCESSORIES

 Threaded connection plates and multi-flange subplates Register 2.9
 Mating connector EN 175301-803 Article no. 219.2002

Technical explanation see data sheet 1.0-100

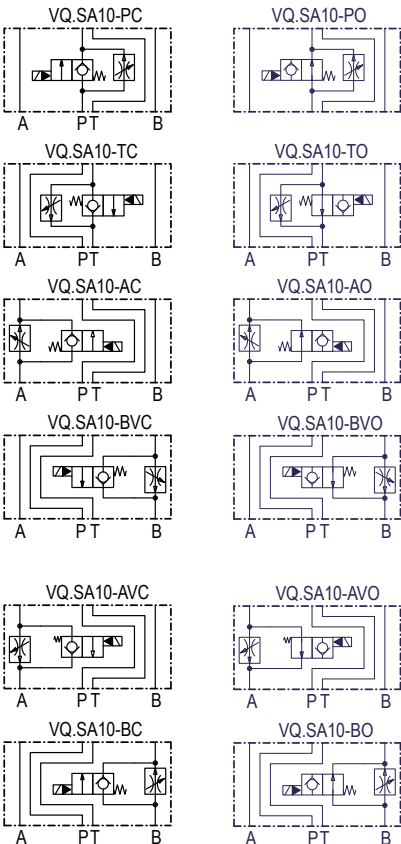
TYPES/DIMENSIONS

Control P, T, A, BV

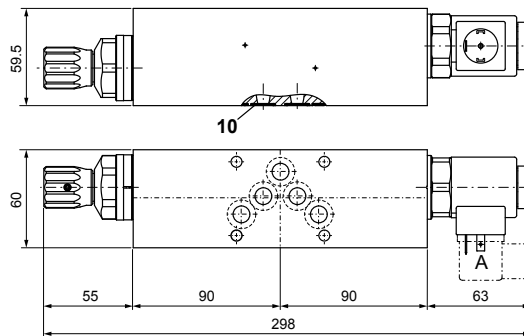

Control AV, B

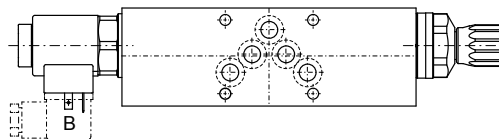

Dimensions of the other setting versions see data sheet 2.5-550