

Solenoid operated spool valve, intrinsically safe

Flange construction

- ◆ 4/2-way impulse valve
- ◆ 4/3-way with spring centred mid position
- ◆ 4/2-way with spring reset
- ◆ $Q_{max} = 20 \text{ l/min}$
- ◆ $p_{max} = 350 \text{ bar}$

NG4-Mini Wandfluh standard

- Ex ia I Ma
- Ex ia II C T5 / T6 Ga
- ⊕ II 1 G Ex ia II C T6, T5
- ⊕ I M1 Ex ia I Ma

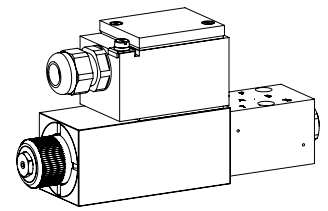

DESCRIPTION

Direct operated solenoid spool valve with 4 connections in 5 chamber design. With the solenoids deenergised, the spool is held in the center position by the spring (4/3), or switched back to the offset position (4/2). With the impulse spool (4/2), the spool is held in the switching position by the detent. Intrinsic safety is achieved by limiting the electric energy in the solenoid circuit by means of a separate intrinsically safe power supply. Therewith sparking is prevented from forming.

APPLICATION

These valves are suitable for applications in explosion-hazard areas, open cast and also in mines. Spool valves are mainly used for controlling direction of movement and stopping of hydraulic cylinders and motors. Miniature valves are used where both, reduced dimensions and weight are important.

CERTIFICATES

	Surface gas and dust	Mining
ATEX / UKEX	x	x
IECEx	x	x
CCC	x	x

The certificates can be found on www.wandfluh.com

ACTUATION

Actuation	Switching solenoid, wet pin push type, pressure tight
Execution	M.Z45 (Data sheet 1.1-185) rotatable in steps of 90 ° and easy exchangeable
Connection	<ul style="list-style-type: none"> ◆ Cable gland for cable $\varnothing 6,5 \dots 12 \text{ mm}$, two phase conductors +/- as well as one ground conductor ◆ Connector socket EN 175301 – 803

SYMBOL

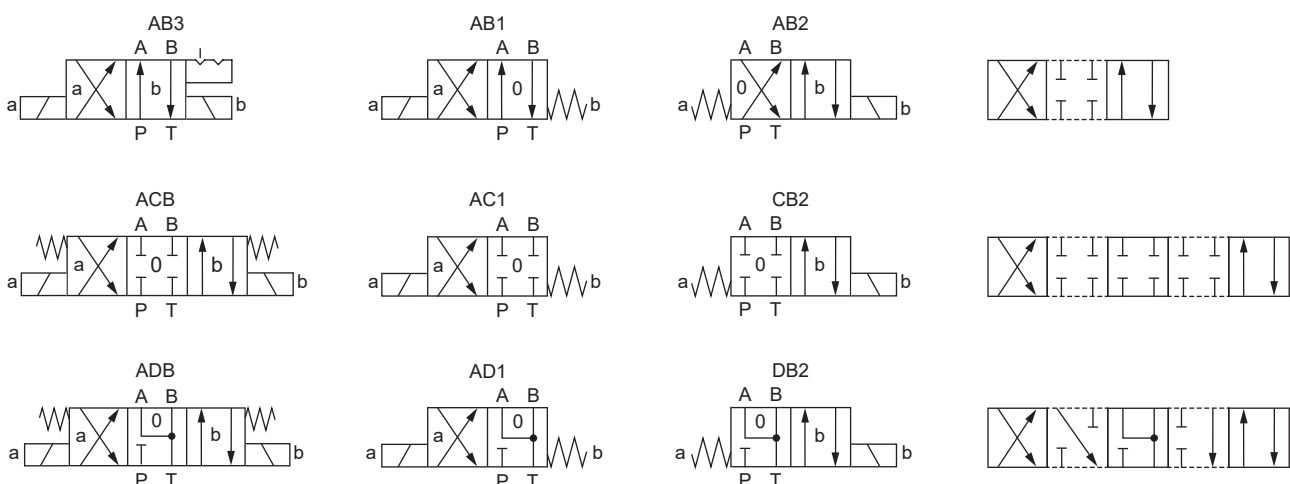

TYPE CODE

		WD Z F A04 - <input type="text"/> - <input type="text"/> - <input type="text"/> / <input type="text"/> / <input type="text"/> - <input type="text"/> # <input type="text"/>	
Pool valve direct operated			
Explosion proof execution Ex ia			
Flange construction			
Mounting interface according to Wandfluh standard, NG4-Mini			
Designation of symbols acc. to table			
Pool specification	Standard <input type="text"/>		
	Low Leakage <input checked="" type="checkbox"/>		
Coil resistance	100 Ω <input type="text"/>		
	152 Ω <input type="text"/>		
Equipment group	I (Mining) <input type="text"/>	only in combination with coil resistance 100 Ω	
	II (Surface) <input type="text"/>		
Connection execution	<input type="text"/>		
	<input type="text"/>		
Sealing material	NBR <input type="text"/>		
	FKM (Viton) <input type="text"/>		
Design index (subject to change)			

1.3-28

GENERAL SPECIFICATIONS

Designation	4/2-, 4/3-spool valve
Construction	Direct operated
Mounting	Flange construction
Nominal size	NG4-Mini according to Wandfluh standard
Actuation	Ex-protection switching solenoid
Ambient temperature	-25...+45 °C (operation as T6) -25...+60 °C (operation as T1...T5)
Weight	2,45 kg (1 solenoid) 4,65 kg (2 solenoids)
MTTFd	150 years

HYDRAULIC SPECIFICATIONS

Working pressure	$p_{max} = 350 \text{ bar}$
Tank pressure	$p_{Tmax} = 200 \text{ bar}$
Maximum volume flow	$Q_{max} = 20 \text{ l/min}$, see characteristics
Leakage oil	See characteristics
Fluid	Mineral oil, other fluid on request
Viscosity range	12 mm ² /s...320 mm ² /s
Temperature range fluid	-25...+45 °C (operation as T6, NBR) -20...+45 °C (operation as T6, FKM) -25...+60 °C (operation as T1...T5, NBR) -20...+60 °C (operation as T1...T5, FKM)
Contamination efficiency	Class 20 / 18 / 14
Filtration	Required filtration grade β 10...16 ≥ 75, see data sheet 1.0-50

ELECTRICAL SPECIFICATIONS

Protection class	IP65
Relative duty factor	Continuous operation
Switching frequency	1'800 / h
Service life time	10 ⁷ (number of switching cycles, theoretically)
Voltage tolerance	± 10 % with regard to nominal voltage
Limiting current at 50 °C	$I_{min} = 90 \text{ mA}$ (100 Ω execution) $I_{min} = 64 \text{ mA}$ (152 Ω execution)
Temperature class	T1...T6
Coil resistance	100 Ω, 152 Ω
Minimum power consumption	$P_{min} = 0,81 \text{ W}$ (100 Ω execution) $P_{min} = 0,62 \text{ W}$ (152 Ω execution)

Note!

Other electrical specifications, recommended power supply and safety-related limits see data sheet 1.1-185

PERFORMANCE SPECIFICATIONS

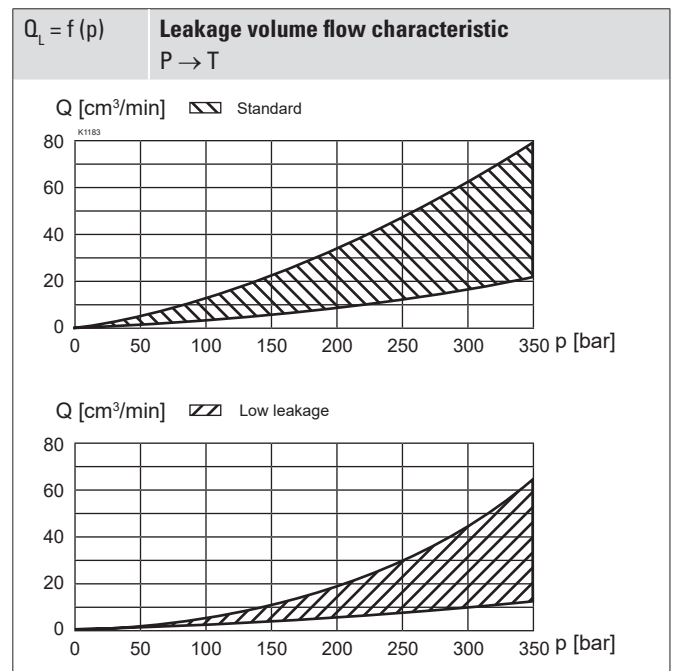
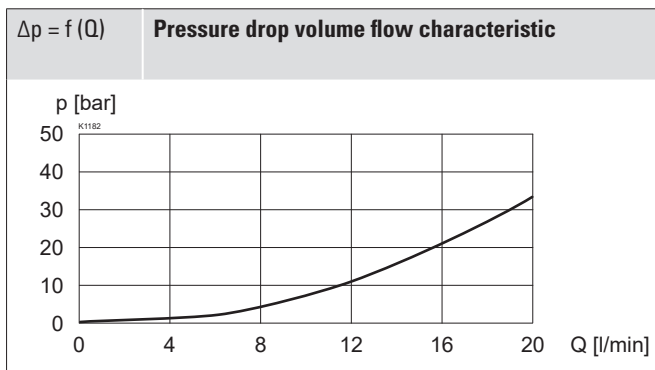
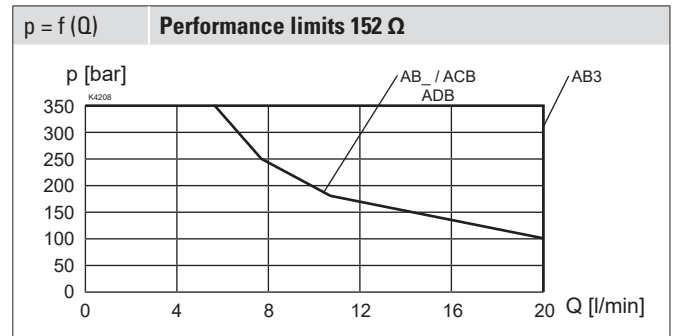
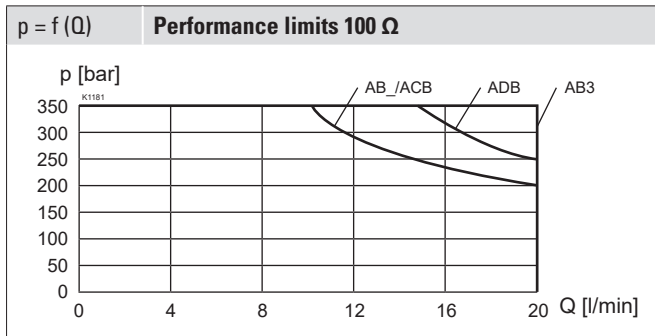
 Oil viscosity $\nu = 30 \text{ mm}^2/\text{s}$

Attention!  If, because of the given operating conditions, during the switching process volume flows occur which exceed the power limit of the valve, these have to be limited by a throttle or an orifice in connection P.
 In case of a continuous flow through, the throttle or orifice, depending on the system behaviour, an additional heating-up of the valve is possible. This has to be appropriately taken into account by the user.

ACCESSORIES

Fixing screws	Data sheet 1.0-60
Threaded subplates	Data sheet 2.9-05
Multi-station subplates	Data sheet 2.9-45
Horizontal mounting blocks	Data sheet 2.9-85
Technical explanations	Data sheet 1.0-100
Filtration	Data sheet 1.0-50
Relative duty factor	Data sheet 1.1-430

STANDARDS

Explosion protection	Directive 2014 / 34 / EU (ATEX)
Mounting interface	Wandfluh standard
Protection class	EN 60 529
Contamination efficiency	ISO 4406

MANUAL OVERRIDE

HB4,5 as standard
 Optionally: HN (K), HB0 (plugged)
 → see data sheet 1.1-311

SEALING MATERIAL

NBR or FKM (Viton) as standard, choice in the type code

SURFACE TREATMENT

Standard:
 -The valve body, the armature tube, the slip-on coil and the plug screw are zinc-nickel coated

ISO 9227 (800 h) salt spray test

DIMENSIONS

4/3-way spool valve (spring centring)

4/2-way spool valve (impulse)

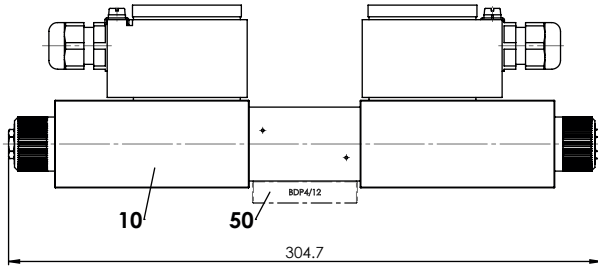

Requirement of the flange surface of the counter piece

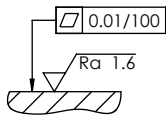

4/2-way spool valve (spring reset)

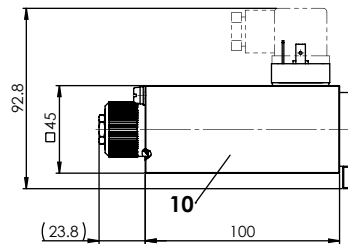
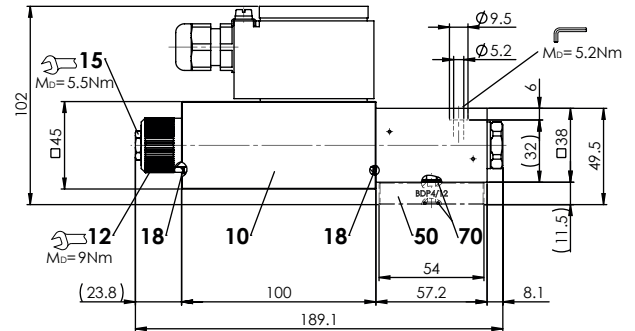

HYDRAULIC CONNECTION

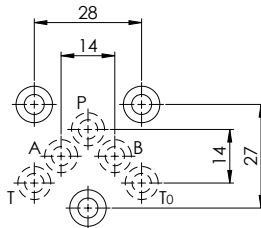

PARTS LIST

Position	Article	Description
10	263.66..	Solenoid coil M.Z45-...
12	032.9614	Knurled nut M22 x 1 x 22
15	253.8000	Manual override HB4,5
50	173.1450	Distance plate BDP4 / 12
-	-	Seal kit

Seal kit consisting of:

18	O-ring	ID 20,35 x 1,78
70	O-ring	ID 5,28 x 1,78

INSTALLATION NOTES

Mounting type	Flange mounting 3 fixing holes for socket head screws M5 x 40 or M5 x 50 (with distance plate BDP4/12)
Mounting position	Any, preferably horizontal
Tightening torque	Fixing screws $M_0 = 5,2 \text{ Nm}$ (screw quality 8.8, zinc coated) $M_0 = 9 \text{ Nm}$ knurled nut

Note! The length of the fixing screw depends on the base material of the connection element.



Attention! For stack assembly please observe the remarks in the operating instructions



COMMISSIONING

Attention! Intrinsically safe valves must be controlled only by a suitable, certified power supply from out of the hazardous area (see Operating Instructions). The selection of the power supply and the wiring must be carried out by qualified personnel. Recommended power supplies and safety-related limit values according to data sheet 1.1-185

